

WORKSTATIONS & COMPUTER FURNITURE



Z/630 PROJECT WORKSTATION, AN INTEGRATION OF BEAUTY AND FUNCTIONALITY BY QUIK LOK'S ITALIAN DESIGNERS TEAM

- For the harmonious integration of your human activity within the high-tech world let Quik-Lok help you improve your flow of creative energy
- The Z/630 project workstation with its own 8-space rack, and the Z/612 companion 12-space rack, are the essence of design and functionality
- From the finest wood laminate tops and shelves to the underlying computer-welded 14-gauge steel with powder-coating black finish, these structures add a modern, elegant look to any work environment
- Available with wood laminate tops in both black and cherry finish

Z/630 CY

- Dual level project desk system with 8-space rack holders and contoured cherry wood tops

Main Shell dimensions:

Height from floor:	28.9" - 73.4 cm
Width:	68.68" - 175 cm
Depth:	23.74" - 60.3 cm
Thickness:	18 mm

Top Shelf dimensions:

Height from floor:	39.33" - 100 cm
Width:	78.35" - 199 cm
Depth:	14.71" - 37.5 cm
Thickness:	18 mm

Overall Width:	78.35" - 199 cm
Overall Depth:	45.78" - 116.3 cm
Metal frame colour:	Black

Options: LPH/T, IPS/16





View of Z/630 BK project desk system set up for use

Z/630 BK

- Dual level project desk system with 8-space rack holders and contoured black wood tops

Main Shell dimensions:

Height from floor:	28.9" - 73.4 cm
Width:	68.68" 175 cm
Depth:	23.74" - 60.3 cm
Thickness:	18 mm

Top Shelf dimensions:

Height from floor:	39.33" - 100 cm
Width:	78.35" - 199 cm
Depth:	14.71" - 37.5 cm
Thickness:	18 mm

Overall Width:	78.35" - 199 cm
Overall Depth:	45.78" - 116.3 cm
Metal frame colour:	Black

Options: LPH/T, IPS/16



Details of Z/630 base equipped with hidden casters for easy mobility and stabilizing plastic feet to compensate for uneven floors

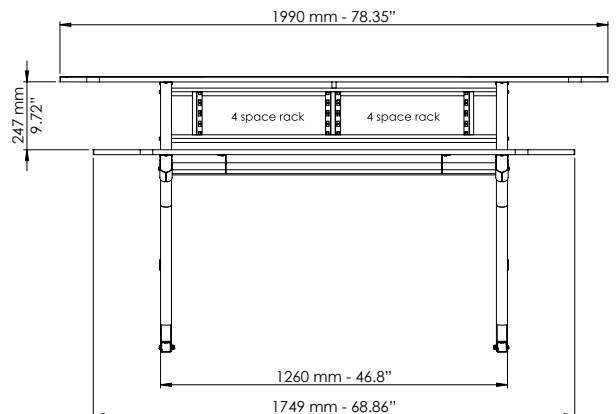
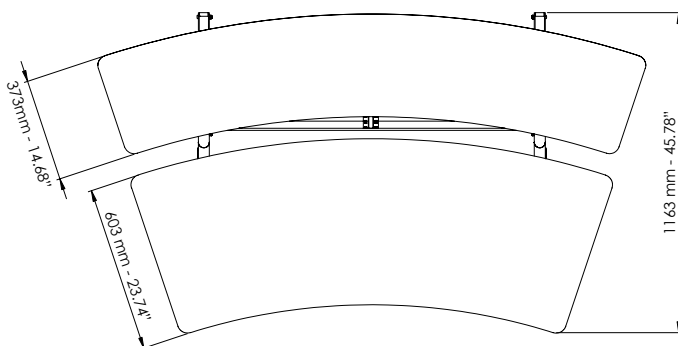

Workstations & Computer Furniture

Z/460 DESIGNER SERIES PROJECT WORKSTATION

- Ergonomically designed for maximum comfort and efficiency
- Sleek, attractive styling adds modern, elegant look to any work environment
- Feature scratch-resistant 3/4" (18 mm) thick laminate shelves, in black finish
- Computer-welded heavy duty steel frame provides tremendous weight capacity
- Powder-coating black enamel finish
- Accommodates all kinds of computer equipment and accessories

Z/460 BK

- Triple Shelf Workstation with black wood tops and pull-out shelf
- Includes a 4-space rack holder (easily removable if not required)

Main shelf dimensions:

Height from floor:	28.8" - 73.2 cm
Width:	44" - 111.8 cm
Depth:	22" - 55.9 cm
Thickness:	3/4" - 18 mm

Top shelf dimensions:

Height from floor:	38.8" - 98.6 cm
Width:	49.25" - 125 cm
Depth:	12.75" - 32.4 cm
Thickness:	3/4" - 18 mm

Pull-out shelf dimensions:

Height from floor:	25.8" - 65.7 cm
Width:	29.8" - 75.7 cm
Depth:	14" - 35.5 cm
Thickness:	3/4" - 18 mm

Overall dimensions:

Width:	49.37" - 125.4 cm
Depth:	33.46" - 85 cm
Height:	38.8" - 98.6 cm
Metal frame color:	Black

Options: LPH/T, IPS/16



View of Z/460BK cable management rear channel

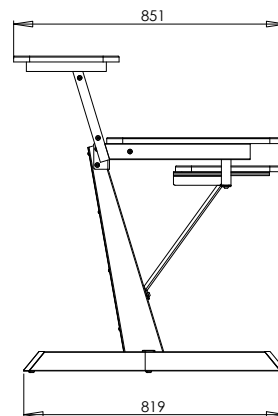
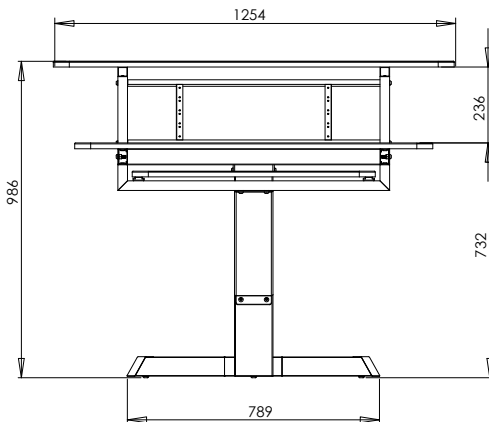

Z/612BK

- 12-Space companion rack stand, with contoured black wood top

Height:	28.9" - 73.5 cm
Width:	24" - 61 cm
Depth:	20.8 - 53 cm
Weight capacity:	200 lb - 90.5 kg

Z/612BK AM

Supplied with 10/32" Whitworth (US thread) bolts & cagenuts

Z/612BK EU

Supplied with 6 mm Metric (European thread) bolts & cagenuts

Top Shelf dimensions:	
Width:	30" - 76 cm
Depth:	23.8" - 60.5 cm
Thickness:	18 mm
Metal frame color:	Black



View showing two possible configurations of Z/460BK project desk system in combination with Z/612BK rack stand

Z/612CY

- 12-Space companion rack stand, with contoured cherry wood top

Height:	28.9" - 73.5 cm
Width:	24" - 61 cm
Depth:	20.8 - 53 cm
Weight capacity:	200 lb - 90.5 kg

Z/612CY AM

Supplied with 10/32" Whitworth (US thread) bolts & cagenuts

Z/612CY EU

Supplied with 6 mm Metric (European thread) bolts & cagenuts

Top Shelf dimensions:	
Width:	30" - 76 cm
Depth:	23.8" - 60.5 cm
Thickness:	18 mm
Metal frame color:	Black



Workstations & Computer Furniture



LPH/T

- Add-on laptop holder for studios and multi-media workstations.
- Can be securely anchored to any table top surface by means of its tightening clamp (adjustable up to 45 mm).
- Can accommodate virtually any size laptop 10.2" to 16.5" (26 to 42 cm) wide and 10.2" to 16.5" (26 to 42 cm) deep. Four stoppers, adjustable in width and depth, will securely anchor any size laptop, without interfering with input/output ports, expansion slots, cd-rw/dvd drivers, A/C adapter sockets placed on either side of the laptop.
- The laptop tray is height and tilt adjustable, and swivels at 360° to allow for ideal positioning.
- Equipped with pull-out mouse tray, that can be positioned on either the left or right side of the laptop, and is retractable for easy storage and transport.

Height adjustment*:	from 10.2" to 14.5" from 26 to 37 cm
Laptop tray dimensions:	10" x 10" 25 x 25 cm
Mouse tray dimensions:	5.3" x 5.3" 13.5 x 13.5 cm
Laptop stoppers width range:	from 10.2" to 16.5" from 26 to 42 cm
Laptop stoppers depth range:	from 10.2" to 16.5" from 26 to 42 cm
Clamp opening.	1.77" - 4.5 cm
Color:	Black

*measured from table top to bottom of laptop tray)



IPS/16

- Add-on universal tablet holder for studios and multi-media workstations.
- Can be securely anchored to any table top surface up to 72 mm thick (2.83") by means of its tightening clamp, but can also be connected to any stand with round tubing diameter of up to 50 mm (1.968").
- Clever, safe and practical design allows musicians to integrate their tablet with existing furniture, for use on stage, production studios, in the rehearsal room or at home.
- Will accommodate virtually any size tablet having side measurements ranging from 111 mm to 301 mm (4.37" to 11.85") and depth ranging from 6.9 mm to 18.7 mm (0.27" to 0.73").
- Flexible yet rugged rubberized plastic stoppers will hold the tablet firmly and securely in place, without interfering with dock connector, speaker, headphone jack, on/off and volume buttons.
- No-wobble, lightweight aluminium plate is designed to ensure full tilt and rotational adjustability, and to switch rapidly from the vertical to the horizontal viewing mode without slipping, for ideal positioning of your tablet.

Weight capacity:	33 lb - 15 kg
Color:	Black



Details of IPS/16 tightening clamp device